

**SQUARE**  
PERFECT

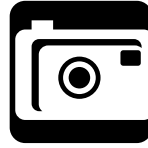

*Make every picture perfect*



**SP4000 VARIABLE POWER  
STUDIO FLASH SET**

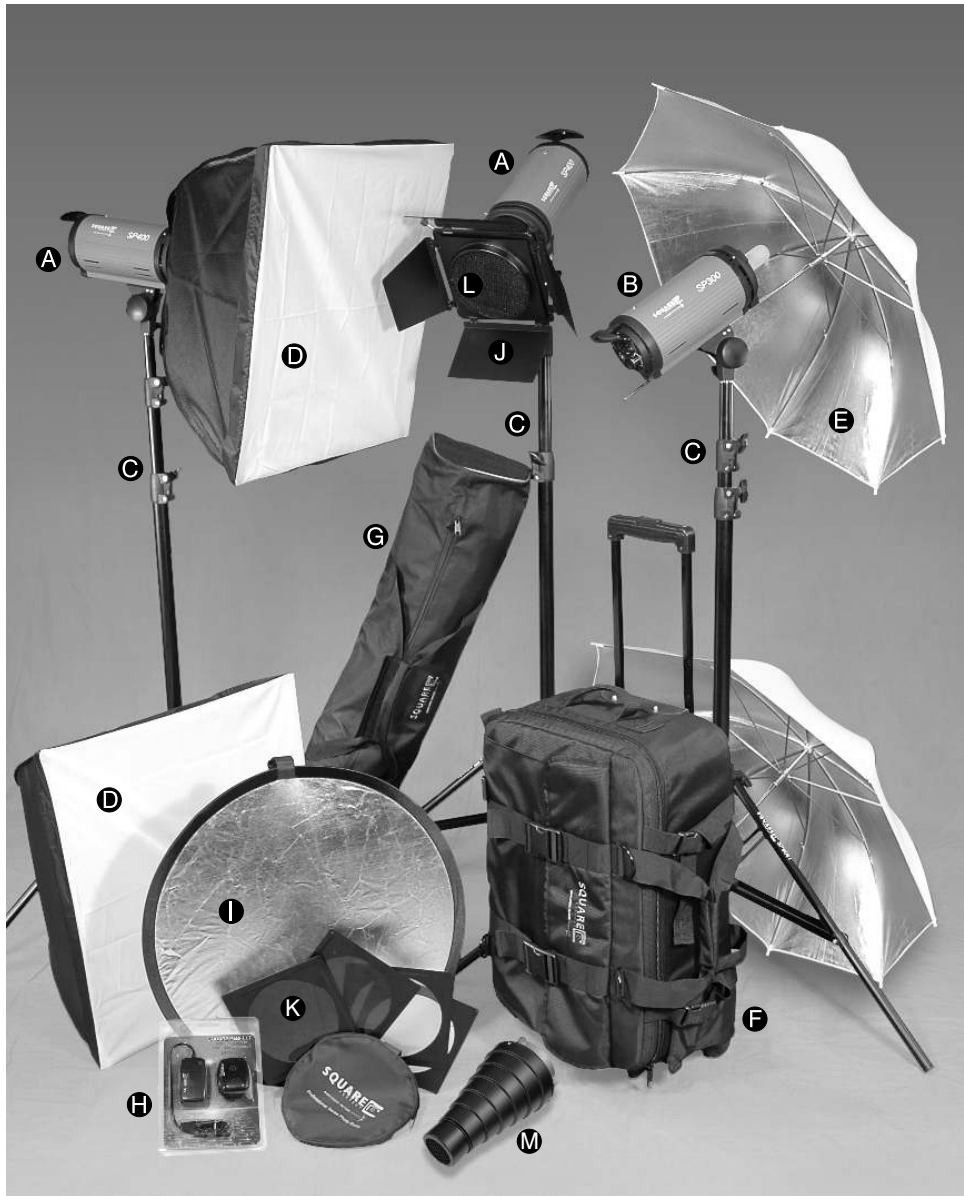

## SP4000 Professional Series Studio Light Kit

- A** Qty. 2 SP4000 Professional Studio Strobes (400 Watt-Seconds) 75-watt modeling light.
- B** Qty. 1 SP3000 Professional Studio Strobe (300 Watt-Seconds) 75-watt modeling light.
- C** Qty. 3 Light Stands (extends 39" to 8'1/2")
- D** Qty. 2 Softbox (24" X 24")
- E** Qty. 2 Umbrella (36" silver reflection umbrella)
- F** Qty. 1 Trolley Case (Carries three strobes and accessories)
- G** Qty. 1 Carry Bag (Carries three light stands and umbrella)

### Accessories:

- H** Qty. 1 Wireless strobe trigger system.
- I** Qty. 1 Collapsible Reflector (32" double sided - Silver/White)
- J** Qty. 1 Four Leaf Barndoor
- K** Qty. 1 Set of 4 Color Gels
- L** Qty. 1 Honeycomb Diffusion Filter
- M** Qty. 1 Narrow Snoot

# SP4000 Flash Studio Kit

Thank you for your purchase of the SP4000 Flash Softbox Studio kit. This manual has been written to help you with the assembly, operating procedures and accessories. Square Perfect's SP4000 Flash Kit is manufactured with the finest material available. Your flash kit will provide many years of quality service with proper care and handling.

Please read this manual carefully before use, and keep it handy for use during break down of equipment. Please read and heed all safety precautions listed in this manual. To order spare bulbs or replacement parts, contact us at [info@squareperfect.com](mailto:info@squareperfect.com). Also check out our extended line of photo equipment now available.

## Flash Studio Kit Includes:



- 1x2 SP400 lamp body.
- 1x1 SP300 lamp body
- 1x3 12' power cord.

Nylon Carry Case. Compartmentalized for easy use. Extra large pockets for accessories. Extend handle and roller wheels.



- 1x3 SP8061 professional heavy duty adjustable light stand. Stand extends from 39" to 8'1/2".



Nylon Carry Case for safe storage and transporting lights and stands.

- 1x1 Flat reflector for creative fill techniques, includes carry case.



- 1 set Red, blue, yellow frosted and honeycomb filter.

Four leaf barndoor set with color filter attached to the flash head.



- 1x1 Snoot will direct light to exact spot without affecting surrounding area.



- 1x2 Four panel softbox set. with lamp connector.



Remove protective cover from mounting tip before attempting to place flash head on stand.

Electronic radio trigger/receiver with sync cord and adaptors.



- 1x2 Umbrella - double layered reflective inside, light proof backing.

## SP300/400 Lamp Head Operation:

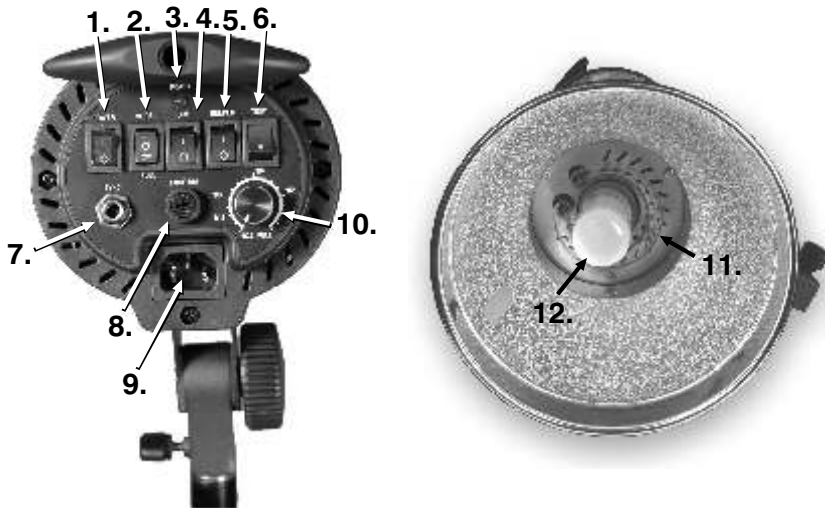

- |                            |                             |                          |
|----------------------------|-----------------------------|--------------------------|
| 1. On/Off electric supply. | 5. On/Off flash ready beep. | 9. Power Receptacle.     |
| 2. Hi/Low, model lamp.     | 6. Flash test.              | 10. Flash variable dial. |
| 3. Flash ready light.      | 7. Sync receptacle.         | 11. Flash ring.          |
| 4. Dim switch.             | 8. Safety fuse.             | 12. Model lamp.          |

## Specifications:

Power Input : AC110-130 volt, 60 Hz  
 Fan Cooled - High temp protected.  
 Flash Power : 300/400ws (joule) in full  
 Guide No. : 120ft/36m ISO100  
 Color Temperature : 5600K  
 Flash-Tube Lifetime : over 8,000 typical flashing  
 Flash Power Setting : 1/32 to full  
 Recharge Time : 0.5-3 seconds in full  
 Flash Duration : 1/1700 sec.  
 Slave Range : 35ft /10m  
 Lighting Range : 55 degree  
 Modeling Power : Halogen 150w  
 Bulb Base : screw  
 Synch Voltage : 5 volt  
 Fuse : 6A  
 Dimension : 14" x 7-1/2"  
 Weight : 6.5 Lb (3.0kg)

## SAFETY PRECAUTIONS:

- Become thoroughly familiar with this product before use. Run through at least one practice assembly and breakdown before you schedule a shoot.
- Make sure that the main voltage corresponds to that stated on the SP lamp. Account for number of lamps in use.
- Never leave the lighting unsupervised when in use. Keep children or incompetent persons away from lighting equipment.
- If the lamp or the cord show sign of wear or damage, it should be replaced or repaired by a qualified electrician before use.
- Wait until the bulb is completely cool before touching or removing it.
- Never use the SP lamp outside in a wet environment.
- Never move the appliance by pulling the cord. Make sure the cords do not come in contact with halogen bulb. Do not wind the cord around the appliance.
- Stand the SP on a flat surface only to prevent toppling.
- Do not touch the metal parts on the lamp while in use, these metal parts will become very hot.

## Softbox Assembly:



1. Pictured is the SP4" lamp ring connector shown with the large end of the flex rod inserted.



2. Small end of flex rod fits into corner pocket on the softbox tent.



3. With three rods inserted into the ring and corners, fold the SP 4" ring into the tent.



4. Next insert the fourth rod into the SP 4" ring. *Note:* Keep the velcro flaps at the ring open to allow sufficient slack.



5. Insert the fourth rod into the pocket on the velcro strap.



6. Push the velcro strap into place just below the lip of the tent. *Note:* the rods take a good deal of force to flex into position.



7. Now close the velcro flaps as shown in the picture.



8. The SP 4" ring can now be attached to the SP 160 flash unit. *DO NOT* over tighten.



9. Next attach the inner diffusion lens with the velcro straps.



10. Attach the outer diffusion lens to velcro patches on the outer edges.

# Technical Notes for the electronic radio trigger device:

The SP Flash Kit is shipped with the DRT-2G electronic radio flash triggering device for your convenience. It is an easy to use device that will give you extra control in the photographic studio environment. The DRT-2G is designed to work with a variety of flash units. We provide a wide range of sync cord adaptors

to fit most popular brands.

The DRT-2G trigger has two channels and uses a 23A battery (installed). The DRT-2G receiver uses two AAA batteries (not included).

1. To use the DRT-2G trigger device, first slide the trigger into the hot shoe found on top on your camera. If a hot shoe is not available, use the sync cord attachment found on the side of the trigger device.



2. Attach the receiver to a remote flash unit. Use the proper sync cord adaptor provided, plug into sync cord socket.

3. Switch the receiver unit ON/OFF button to the ON position. Press the test button located on the top of the trigger unit. You will see a twinkling of the LED on the receiver unit. This indicates the trigger is working properly and is locked-in on a working channel of the receiver.



4. Switch the remote flash unit power switch to the ON position with the DRT-2G receiver attached. Push the test button on the DRT-2G trigger, it should trigger the remote flash unit.

5. To change channels on the DRT-2G trigger, slide the channel switch on the side of the trigger device to the opposite position. Next press the power switch on the receive unit twice to reset the receiver.

To order spare bulbs or replacement parts, contact us at [info@squareperfect.com](mailto:info@squareperfect.com). Also check out our extended line of photo equipment.



[www.squareperfect.com](http://www.squareperfect.com)